



GENERATIONS AHEAD IN SONAR & ULTRASONIC TECHNOLOGY

Massa Model M3 and M3is Family of Wireless Ultrasonic Level Sensors

Standard and Intrinsically Safe Versions

The Massa Model M3 Family consists of battery operated wireless level sensors that intercommunicate using ZigBee RF Modules. These sensors produce detection ranges from as close as 4 inches (100 mm) to 35 feet (11 meters). Incorporating state-of-the-art ultrasonic technology, the sensors provide precision non-contact distance measurement for liquid level or industrial process control. The M3 Family of Wireless Level Sensors stand out over all other systems because of their affordability, extraordinary ease of operation and the ability to be set up without using a target. They transmit narrow beam sound pulses, process return echoes, and report the distance to the target.

The M3 obtains and records range, temperature, battery voltage, sensor parameters, historical data and other information. An internal pushbutton switch is used to commission the sensor onto the ZigBee network and a LED is used to identify the operating mode. The package is rated for emersion and high pressure wash-down in accordance with IP67. The batteries are accessible for replacement.

All of the sensors in the M3 Family are available in two versions. Standard M3 Sensors are designed for operation in typical industrial applications. For use in hazardous environments, intrinsically safe M3is Sensors are also available. They are certified by Factory Mutual as meeting the requirements of Class 1 Div 1 (C1D1), all groups.

All of the models in the M3 Family of Sensors include an advanced diagnostic feature that will retrieve the ultrasonic waveform for analysis and display it on a computer using the sensor's software. Users will find this very useful for debugging and correcting more difficult applications without using an oscilloscope.

Other features include a totally sealed Kynar housing containing an industry standard 2 inch NPT fitting for mounting, operation from -30°C to 65°C with built-in temperature compensation.

For more information visit our web site at www.massa.com.

MASSA PRODUCTS CORPORATION

280 Lincoln St., Hingham, MA 02043 U.S.A.

Tel: 781-749-4800 Fax: 781-740-2045

Toll Free in USA: 800-962-7543

e-mail: sales@massa.com



FEATURES

- Wireless
- Intrinsically Safe Versions are Available (M3is Sensors)
- Low Power
- Rugged
- 2" NPT Mounting Fitting
- Plug & Play Setup
- No Target Needed
- Built-in Temperature/Sound Speed Compensation

APPLICATIONS

- Liquid Level Monitoring
- Process Control
- Mechanical Positioning
- Roll Diameter Measurement
- Automatic Filling Operations
- Automatic Packaging
- Bulk Level Control

M3 and M3is SPECIFICATIONS

Ultrasonic Frequency	Model M3/150: 150kHz, Model M3/95: 95kHz, Model M3/50: 50 kHz
System Beam Angle	8 degrees conical
Sensing Range	Model M3/150: 4" to 8', Model M3/95: 12" to 13', Model M3/50: 14" to 35'
Operating Temperature	-30°C to 65°C, relative humidity 0 – 95%, non-condensing
Ultrasonic range response time	Approximately 150mS to 500mS when programmed to default mode
Temperature probe	Internal for speed of sound compensation
LED	Red and Green status indication
Switch for provisioning	Internal pushbutton switch for commissioning sensor onto the network
Housing Material	Kynar base, cover, and transducer
Housing Thread	2" NPT
Housing IP Rating	IP67
Radio (100mW)	Onboard 100mW with whip antenna
Data Acquisition Interval	Programmable wake up and collect data from 10 seconds to 194 days
Historical data saved	Up to 111 events of sensor data saved in memory including target range, temperature, battery voltage, sensor status, and an Event counter
Sensitivity Adjustment	Programmable
Application Firmware	Reprogrammable
Power	3 Lithium Energizer model L91 AA size 1.5V batteries
Battery Life	3-5 years (4-12 data reports per day) with Energizer L91 batteries Lifespan can be affected by temperature and reporting rate
Battery Voltage (minimum)	3.1V; however, once below 3.6v the Energizer L91 capacity diminishes at an accelerated rate
Intrinsically Safe	Models M3/150is and M3/95is meet Class 1 Div 1 (C1D1), all groups

All Specifications subject to change without notice

Outline Drawing of M3/150 and M3/95 Sensors (inches)

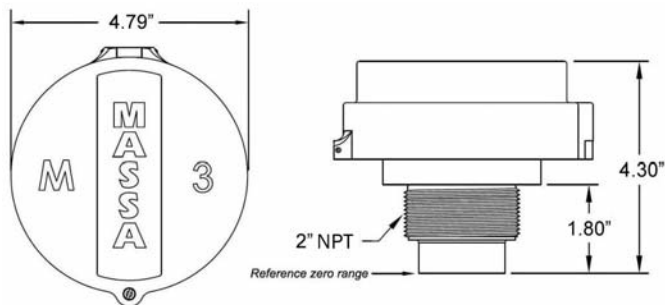

Outline Drawing of M3/50 Sensors (inches)

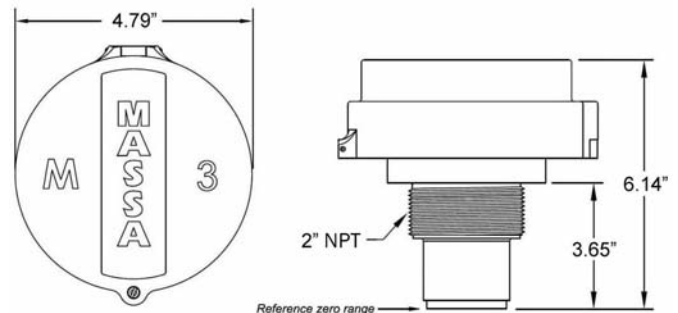

MASSA PRODUCTS CORPORATION

280 Lincoln St., Hingham, MA 02043 U.S.A.

Tel: 781-749-4800 Fax: 781-740-2045

Toll Free in USA: 800-962-7543

e-mail: sales@massa.com

www.massa.com