

SPECIFICATION

Model TR-1077A Deep Water Sub-Bottom Profiling Transducer

The Massa Model TR-1077A is a high power underwater transducer that operates in the 3.5 kHz region. The design is based on the Massa TR-1075 Transducer, except it has been modified to work at depths greater than 20,000 feet. An outline drawing of the TR-1077A, which weighs 50 lbs. in air, is shown on Page 2. The nominal responses of a typical TR-1077A is provided in the following curves.

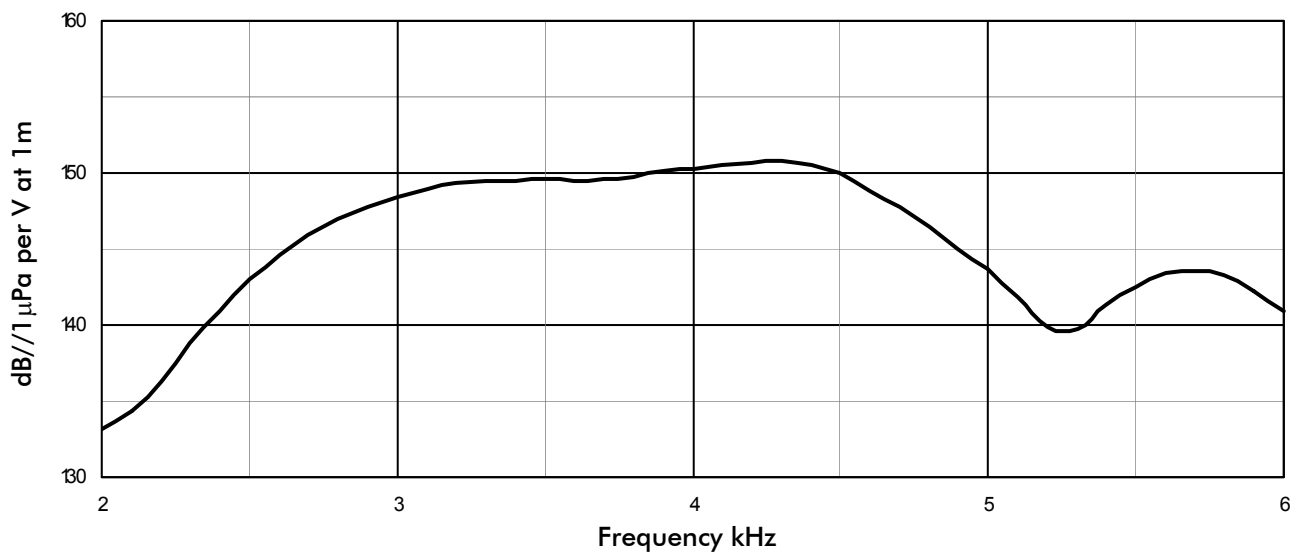

TR-1077A Nominal Constant Voltage Transmitting Response

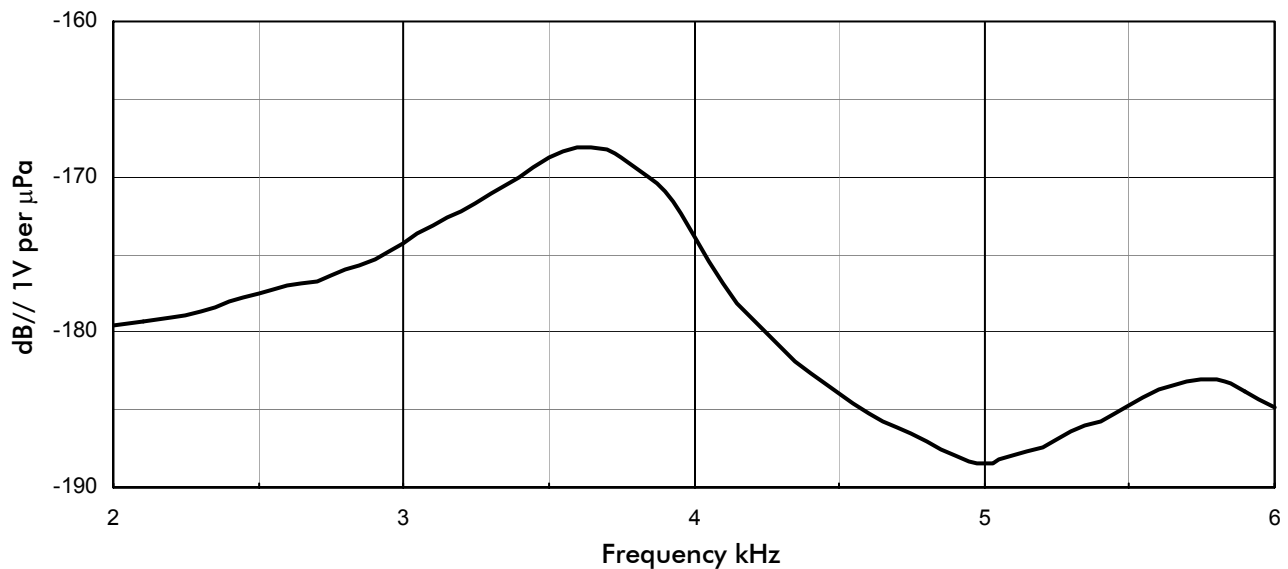

TR-1077A Nominal Open Circuit Receiving Response

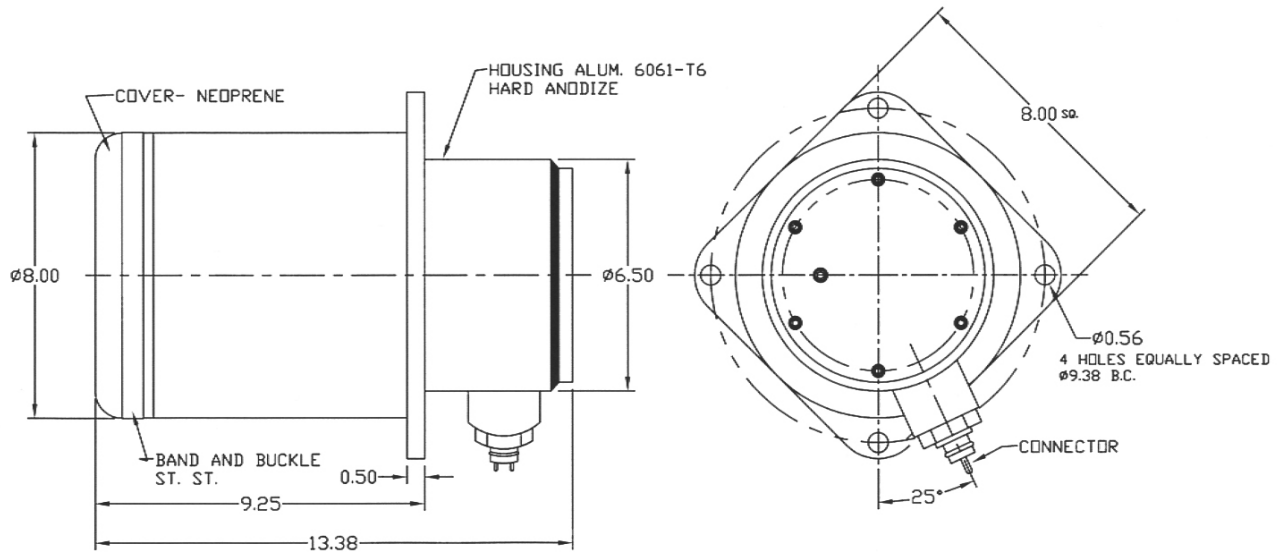

TR-1077A Outline Drawing
(Dimensions in Inches)

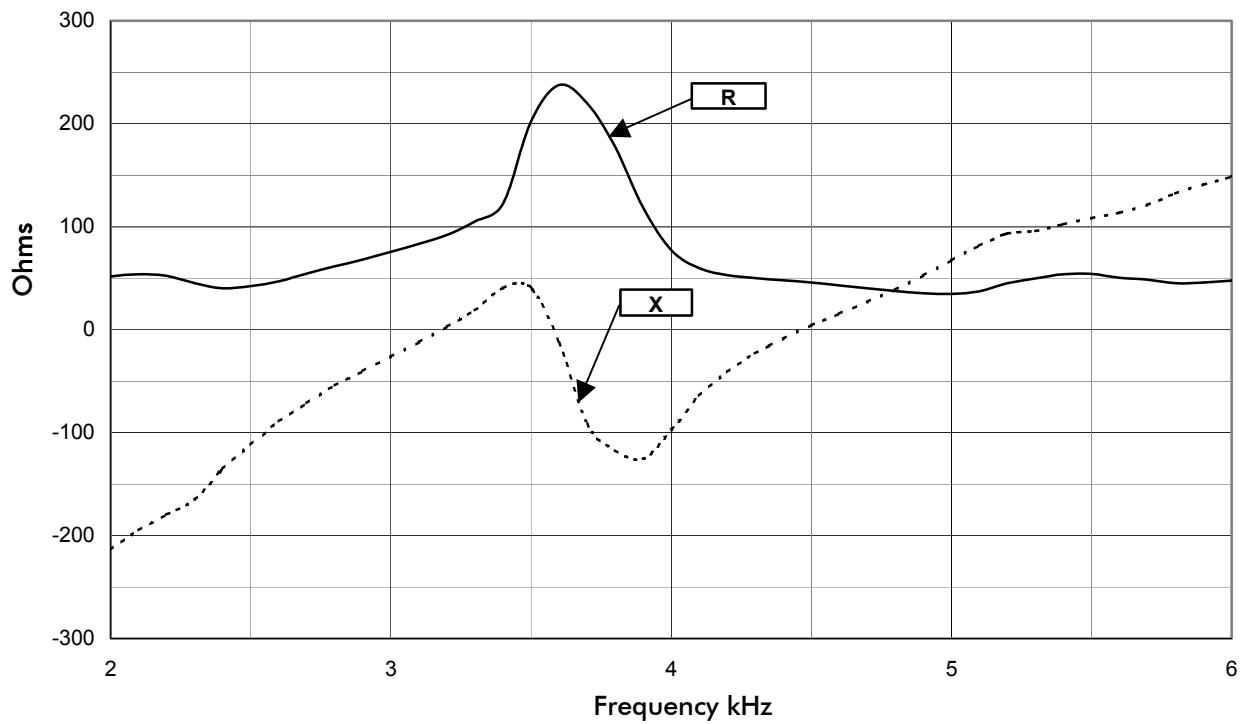

TR-1077A Nominal Resistance, R, and Reactance, X

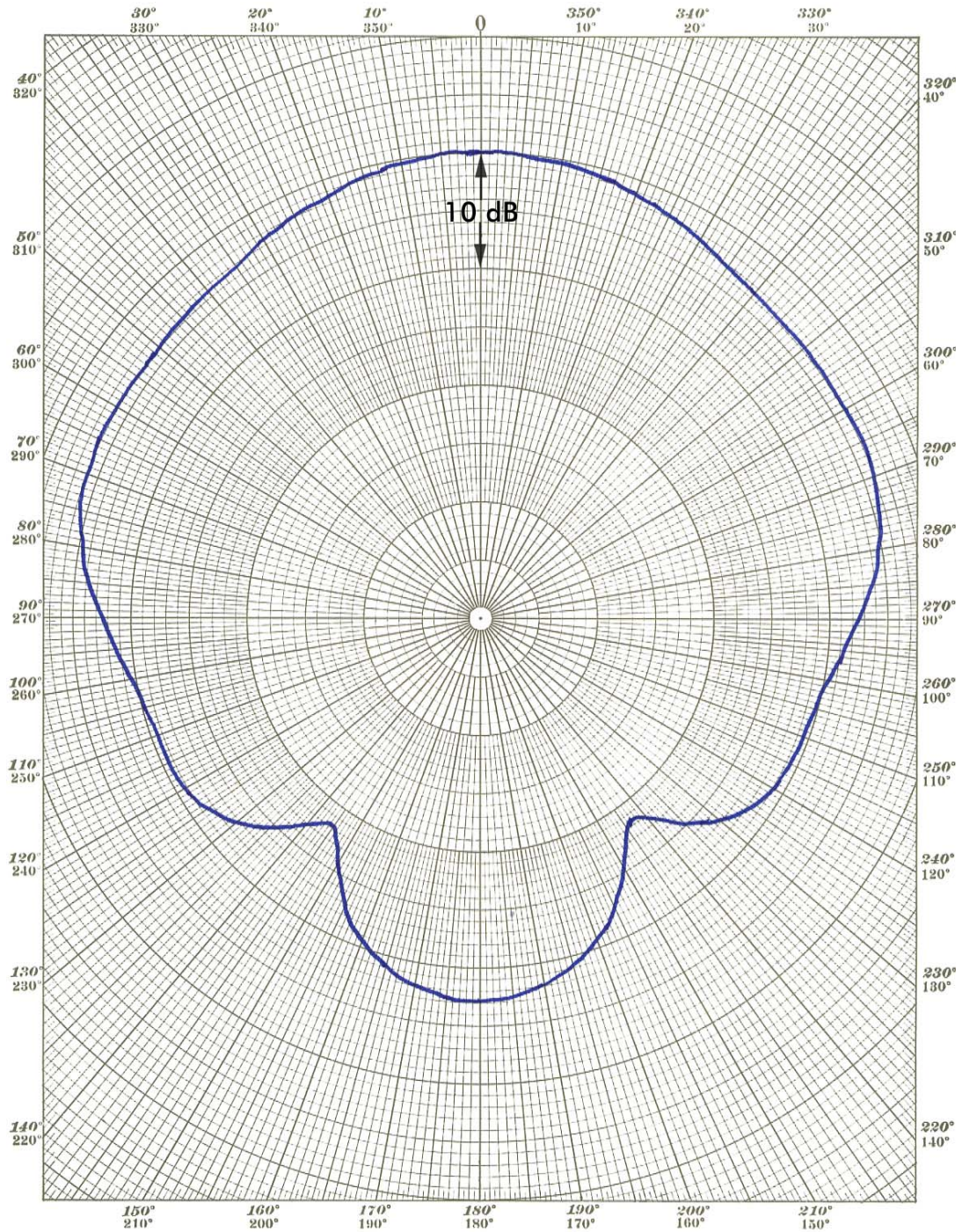

TR-1077A
Nominal Directional Pattern
3.5 kHz